

CME 323 230V/1N/50Hz - 7 Kg / 5Kg

EuroChef

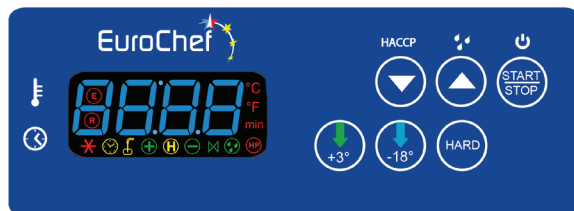

PANNEAU DE COMMANDE

Capacité



7 KG

+90°C → +3°C



5 KG

+90°C → -18°C

Pour bacs GN 2/3
354 mm x 325 mm

3

n° 2 Bac glace (mm) 360x165x120H
n° 1 Bac glace (mm) 360x250x80H



Caractéristiques techniques

Alimentation	230V/1N/50HZ
Code produit	CME 323
Largeur ext.	600 mm
Hauteur ext.	400 mm
Profondeur ext./Porte ouverte	600 (1000) mm
Capacité GN 2/3	3
Compresseur	Hermetique
Gaz Refrigerant	650 g - R404A
Capacité refroidissement rapide (+90°C/+3°C)	7
Capacité surgélation (+90°C/-18°C)	5
Puissance absorbée	700 W - 3,8 A
Poids net/brut	41 Kg / 48 Kg

CME 323 EUROCHEF 230V-1N-50HZ-000.indd

CME 323 Cellule de Refroidissement rapide et surgélation

EuroChef

16, Avenue Carnot
76250 DEVILLE LES ROUEN
FRANCE

CME 323 230V/1N/50Hz - 7 Kg / 5Kg

EuroChef

CME 323 Cellule de Refroidissement rapide et surgélation

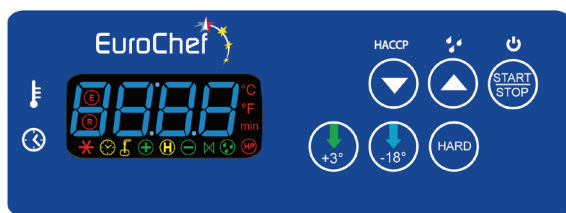
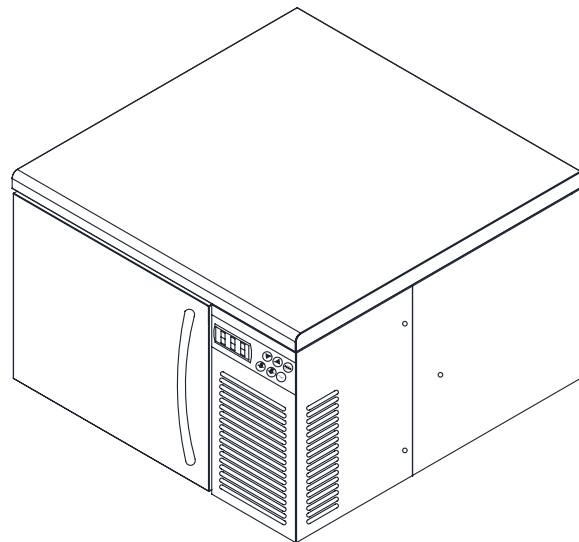
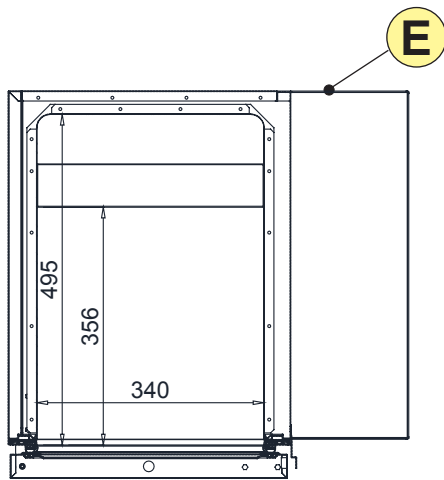
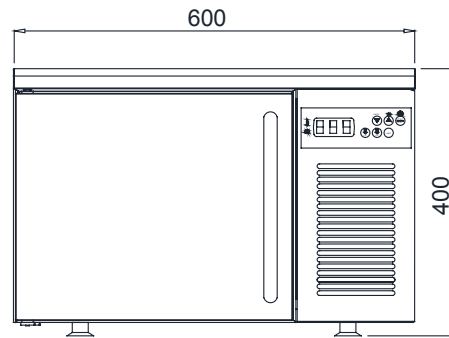
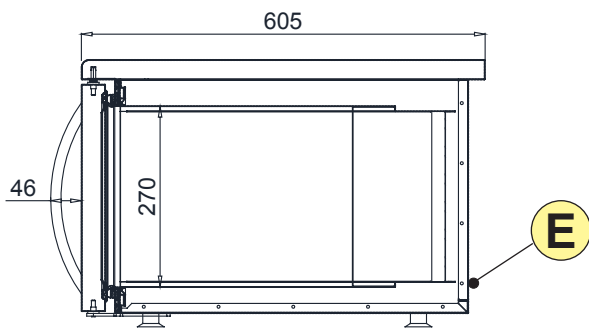

PANNEAU DE COMMANDE

E ALIMENTATION
ELECTRIQUE

CME 323 EUROCHEF 230V-1N-50HZ-000.indd

EuroChef

16, Avenue Carnot
76250 DEVILLE LES ROUEN
FRANCE